

Reliable, silent and dry.



Photo courtesy of Azimut-Benetti



EVA 17 shown

KEY BENEFITS

- Quiet operation, easy to install and maintain
- Wide range of sizes from 3.000 to 24.000 BTU/h
- Unique 'Dry Pan' system ensures the condensate tray is fully draining (even when heeling)
- Powerful yet quiet blowers with easy alignment system to improve air flow
- Anti-vibration mounting system as standard
- Silenzioso e semplice da installare
- Ampia gamma, da 3.000 fino a 24.000 BTU/h
- Innovativo sistema 'Dry Pan' per assicurare il perfetto drenaggio dell'acqua di condensa
- Ventilatori potenti, silenziosi e orientabili per migliorare la circolazione dell'aria
- Sistema anti-vibrazioni fornito come standard

THE PRODUCT

The new EVA fan coils are a major step forward in both design and performance, the result of a 25 years' experience and knowledge in the manufacture of marine air conditioning systems. Our new EVA series overcomes the main critical issues of marine air conditioning systems: effective removal of condensate water, blower position and efficiency and reduced noise and vibration.

The new Climma 'Dry pan' system ensures that all condensation water produced by the air conditioner drains away completely. To achieve this the insulated stainless steel condensate tray is deeper with an angled base ensuring all the water flows to the welded drain point. For sailing boats there are 2 further optional drain points to provide additional drains for when the boat is heeling.

All Climma fan coils are fitted with powerful blowers. The blowers are extremely quiet in operation and are fully adjustable on installation so they can be aligned correctly to the duct run, maximising efficiency of the air distribution.

EVA fan coils are all fitted with Climma's specially developed anti-vibration mounts stopping the transfer of structure borne noise and vibration from the unit.

Available in 11 sizes from 3.000 to 24.000 BTU/h capacity all with optional strip heaters for added comfort as required.

I nuovi fan coil EVA, risultato di 25 anni di esperienza nel settore del condizionamento nautico, sono la perfetta combinazione di tecnica e di design.

I fan coil EVA risolvono infatti le principali problematiche del condizionamento nautico: l'effettiva rimozione dell'acqua di condensa, il posizionamento e l'efficienza dei ventilatori e la rumorosità del fan coil.

Il nuovo concetto Dry Pan è stato studiato per ridurre drasticamente il residuo di condensa. Tutti i fan coil EVA, dotati di una vasca in acciaio inox isolata, sono accessoriati con scarichi di condensa multipli nelle sezioni più basse, a cui si possono aggiungere su richiesta altri due scarichi per andare incontro ad eventuali esigenze di installazioni custom o a condizioni di navigazione con imbarcazione sbandata.

I fan coil EVA sono facili da installare e sono stati studiati con un comodo e potente ventilatore che può essere ruotato senza viti a seconda delle proprie esigenze, così da massimizzare l'efficienza nella distribuzione dell'aria.

Tutti i modelli sono equipaggiati con l'innovativo sistema anti-vibrazioni Climma, così da ottenere un fan coil tra i più silenziosi della sua categoria.

I nostri fan coil EVA sono disponibili da 3.000 a 24.000 BTU/h con l'opzione a riscaldamento elettrico su richiesta.

Reliable, silent and dry.

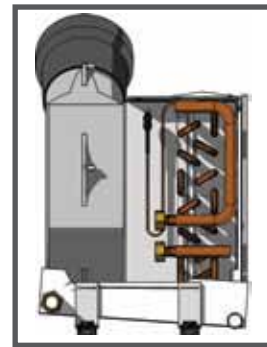
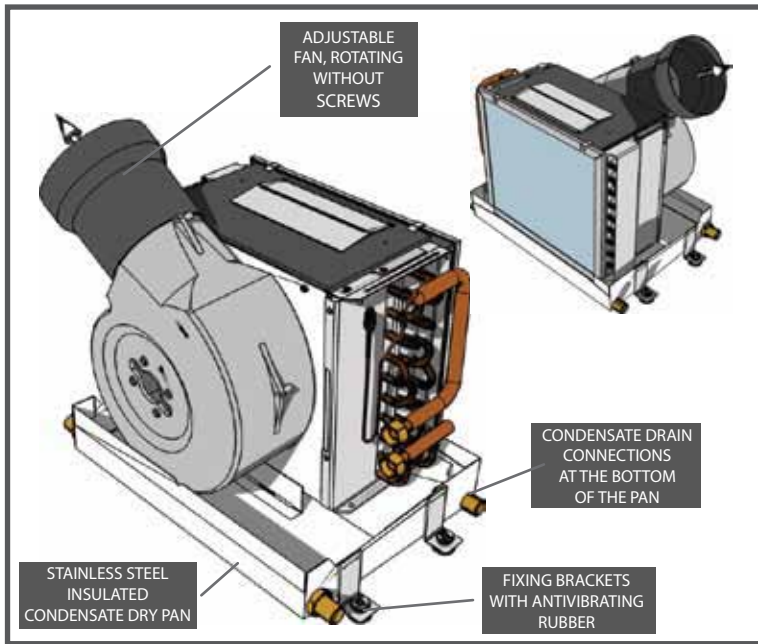

(Electrical control box not shown)

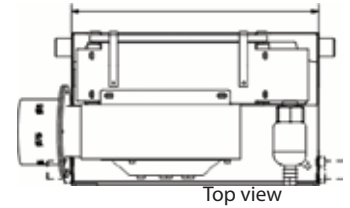

Top view

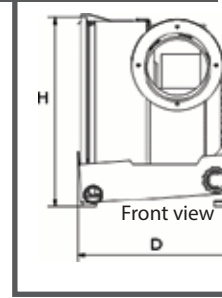

Front view

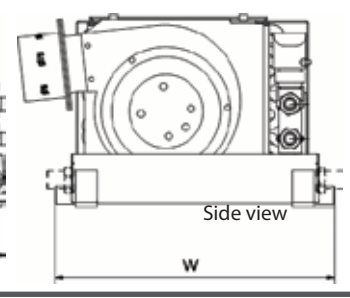

Side view

TECHNICAL SPECIFICATIONS

	Product Code	Nominal Btu/h	Air Flow (m ³ /h)	Fan (nr)	Duct (mm)	W Fan	Heater Power (W)	Weight (kg)	Size WxDxH (mm)	
	EVA 3	MEVA3J	3000	176	1	75	56	-	6,0	322x178x219
	EVA 4,5	MEVA45J	4500	291	1	100	125	-	6,4	377x288x304
	EVA 4,5 + EH	MEVA45EJ	4500	291	1	100	125	1300	6,4	377x288x304
	EVA 7	MEVA7J	7000	311	1	100	125	-	7,6	377x308x304
	EVA 7 + EH	MEVA7EJ	7000	311	1	100	125	1300	7,6	377x308x304
	EVA 9	MEVA9J	9000	527	1	125	235	-	8,0	377x288x304
	EVA 9 + EH	MEVA9EJ	9000	527	1	125	235	1300	8,0	377x288x304
	EVA 13	MEVA13J	13000	537	1	125	235	-	8,7	377x308x304
	EVA 13 + EH	MEVA13EJ	13000	537	1	125	235	1300	8,7	377x308x304
	EVA 15 SLIM	MEVA15SJ	15000	615	2	2x100	2x125	-	15,3	651x308x408
	EVA 15 SLIM + EH	MEVA15SEJ	15000	615	2	2x100	2x125	2600	15,3	651x308x408
	EVA 15 EXTRA SLIM	MEVVA15SJ	15000	615	2	2x100	2x125	-	13,3	651x300x308
	EVA 15 EXTRA SLIM + EH	MEVVA15SEJ	15000	615	2	2x100	2x125	2600	13,3	651x300x308
	EVA 17	MEVA17J	17000	915	1	150	355	-	15,0	465x387x371
	EVA 17 + EH	MEVA17EJ	17000	915	1	150	355	2000	15,5	465x387x371
	EVA 17 SLIM	MEVA17SJ	17000	1080	2	2x125	355	-	18,5	651x408x308
	EVA 17 SLIM + EH	MEVA17SEJ	17000	1080	2	2x125	355	2600	18,5	651x408x308
	EVA 17 EXTRA SLIM	MEVVA17SJ	17000	1080	2	2x125	2x235	-	15,5	651x300x308
	EVA 17 EXTRA SLIM + EH	MEVVA17SEJ	17000	1080	2	2x125	2x235	2600	15,5	651x300x308
	EVA 24 SLIM	MEVA24SJ	24000	1080	2	2x125	2x235	-	18,0	651x408x308
	EVA 24 SLIM + EH	MEVA24SEJ	24000	1080	2	2x125	2x235	2600	18,0	651x408x308
	EVA 24 EXTRA SLIM	MEVVA24SJ	24000	1080	2	2x125	2x235	-	16,0	651x300x308
	EVA 24 EXTRA SLIM + EH	MEVVA24SEJ	24000	1080	2	2x125	2x235	2600	16,0	651x300x308

Get the brochure with all the technical specs!



GOES WITH

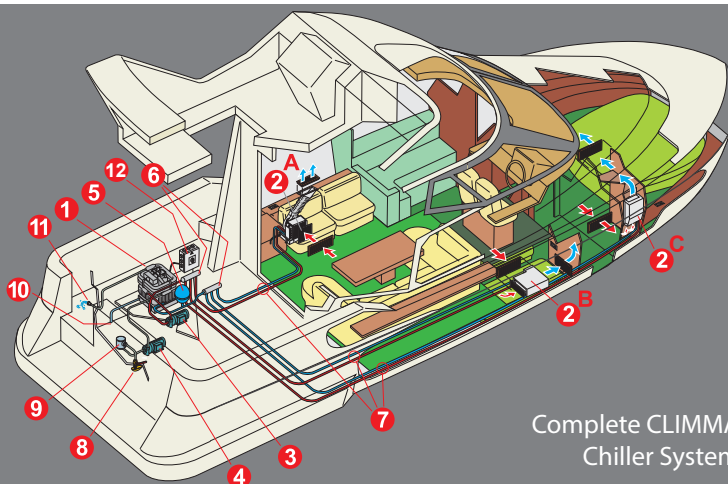

Complete CLIMMA Chiller System

System Components

- 1 Chiller system
- 2 A - FANCOIL EVA
- 2 A - Electrical Control Box (PWM | Mechanic)*
- 2 B - fancoil FC model, C - FCV model
- 3 Fresh Water Pump
- 4 Sea Water Pump
- 5 Expansion Tank
- 6 Manifolds
- 7 Hoses to bring water to/from the fancoils
- 8 Sea water intake
- 9 Water filter
- 10 Condensate drain outlets
- 11 Sea water exit
- 12 Digital Display with Domotic Control MODBUS RS585

*Check our website or the fancoil's Control Boxes brochure to get more infos.



COMPANY WITH QUALITY MANAGEMENT SYSTEM CERTIFIED BY DNV = ISO 9001:2008 =



Penguin Refrigeration Ltd
Unit 2b, Alexandria Park, Penner Road, Havant, Hampshire, PO9 1QY
TEL 02392 453430 EMAIL sales@penguinfrigo.co.uk
www.penguinfrigo.co.uk