

INSTALLATION INSTRUCTIONS 1-6 MUST BE FOLLOWED TO VALIDATE THE WARRANTY

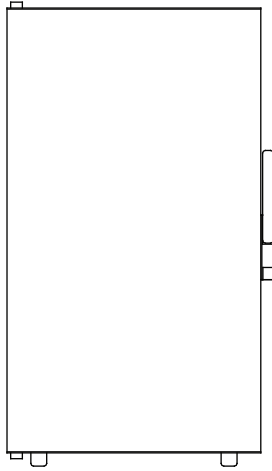

- | | | |
|----------|---------------------------|--------------------------|
| 1 | Minimum Space Requirement | <input type="checkbox"/> |
| 2 | Drainage | <input type="checkbox"/> |
| 3 | Electrical | <input type="checkbox"/> |
| 4 | Fitting | <input type="checkbox"/> |
| 5 | Compressor Installation | <input type="checkbox"/> |
| 6 | Thermostat | <input type="checkbox"/> |

Tick

INSTALLATION NOTES -MS 115 IN (G51365)

1 RECOMMENDED SPACE REQUIREMENTS

When installing the cabinet it is essential that + - 5mm is left to either side and top of the cabinet to allow for sufficient air circulation. 40mm must also be left at the back of the cabinet to allow for pipes.

CABINET DIMENSIONS

Width:	480mm
Height:	840mm
Depth: (excluding door)	435mm
Door:	50mm

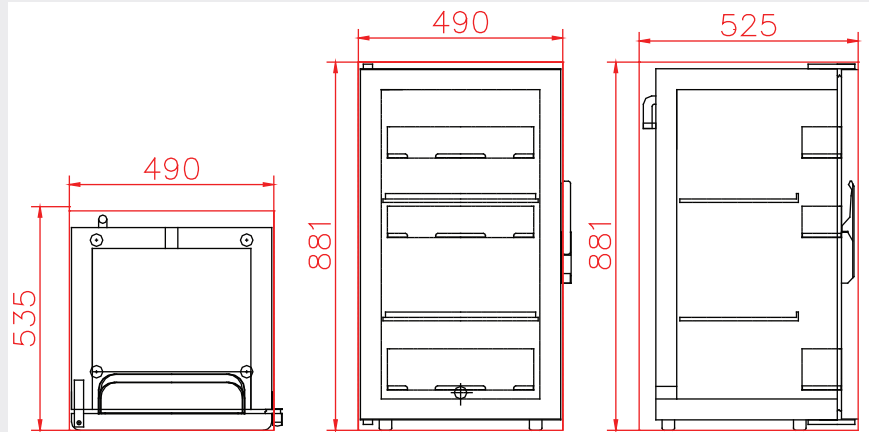

Recommended space required around cabinet (with remote mounted compressor) to allow for sufficient air circulation: 490(w) x 881(h) x 535(d)mm

2 DRAINAGE

All fridge drains **MUST** be fitted with U-bends and must be connected to the food hygiene grey water system.

All fridges will be supplied with a drain fixing kit which allows the drain to be installed correctly with a U-bend.

The drain fixing kit must be installed in a suitable position where the pigtail hangs vertically to allow a sufficiently sized water trap to be created (see drawing). It must be located below the drain exit (A).

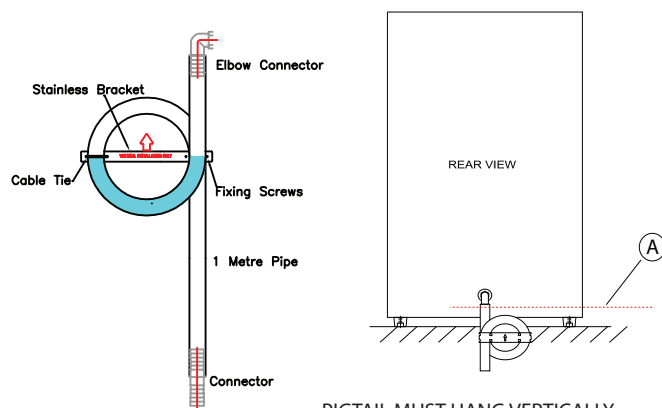

PIGTAIL MUST HANG VERTICALLY

3 ELECTRICAL

MULTIVOLTAGE CONTROLLER

Supply Voltage 12/24v and or 110/220v 50~60hz

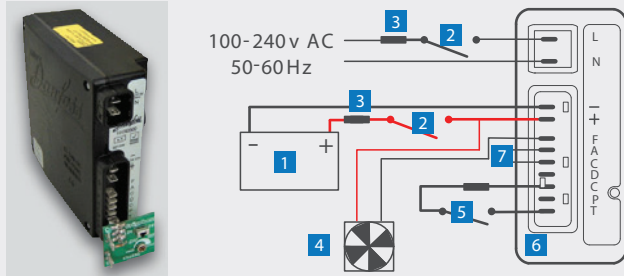

- 1 Battery
- 2 Isolation switch
- 3 Fuses correctly rated (DC 12v 15 amp - 24v 8 amp) (AC 220v 4 amp)
- 4 Fan DC
- 5 Thermostat
- 6 Optional speed board
- 7 DC light

BASIC CONTROLLER

Supply Voltage 12/24v

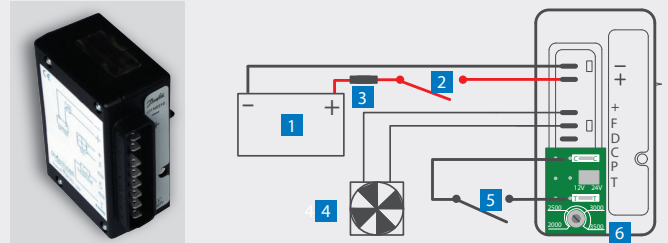

- 1 Battery
- 2 Isolation switch
- 3 Fuse (12v 15amp- 24v 8amp)
- 4 Fan
- 5 Thermostat
- 6 Optional speed board

4 FITTING

FRONT FIXING

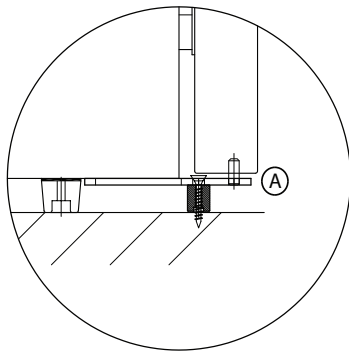

FIXING BRACKETS

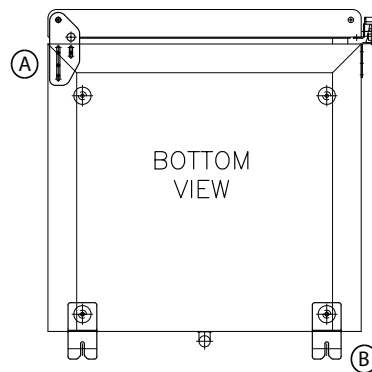

BACK FIXING

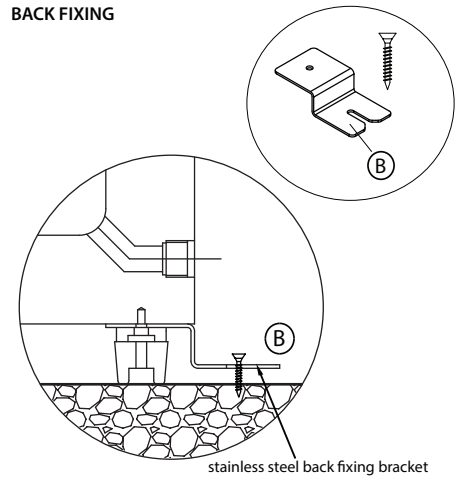

5 COMPRESSOR INSTALLATION

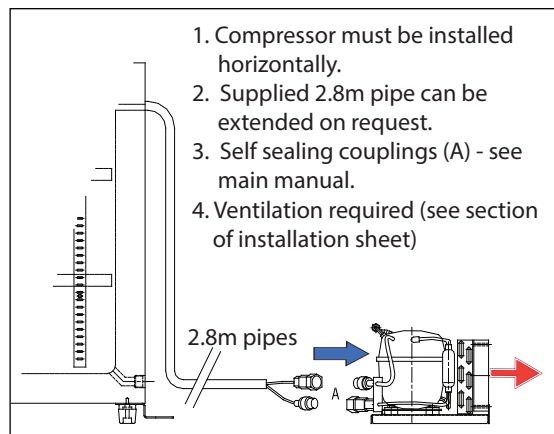

1. Compressor must be installed horizontally.
2. Supplied 2.8m pipe can be extended on request.
3. Self sealing couplings (A) - see main manual.
4. Ventilation required (see section of installation sheet)

6 THERMOSTAT

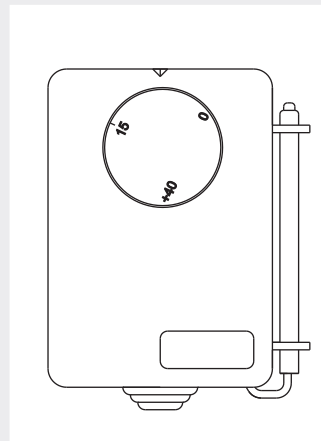

Mechanical Thermostat 0c to 40c

1. Temperature is shown on dial in degrees centigrade.
2. Use the indicator mark at the top of the thermostat to align the dial.
3. Recommended setting +5 for a fridge.

4 PRE-COMMISSIONING CHECKS

PRE-CHECKS 1st RUN

1. Check all refrigerant pipes have been connected by plumbers (ensure couplings connections are fully made).
2. Check all electrical connections are made by electricians.
3. Check door is fitted and closing fully.

PRE-COMMISSIONING 1st RUN

1. Turn on main power and set thermostat to + 5
2. Check compressor is running.
3. **Cabinet should then be left to cool before carrying out commissioning.**

5 COMMISSIONING

PLEASE ENSURE PRE-COMMISSIONING CHECKS ARE CARRIED OUT BEFORE COMMISSIONING CABINET

TO TEST FRIDGE

1. Turn on power to cabinet
2. Set temperature on internal thermostat to + 5
3. Check compressor is running
4. Check hidden evaporator inside cabinet is cooling
5. When cabinet reaches + 5, check compressor turns off

TICK BOX

<input type="checkbox"/>
<input type="checkbox"/>
<input type="checkbox"/>
<input type="checkbox"/>
<input type="checkbox"/>

ADDITIONAL CHECKS

Once cabinet has been confirm as working, turn on fridge and carry out the following additional checks:

1. Check drain is connected and U-bend fitted
2. Check drain is draining properly by pouring 1/2 bucket of water down it
3. Check interior light is switching ON/OFF when door is opened and closed
4. Check door heater seal is working (use infared thermometer over grey plastic)
2. Check shelves are installed correctly and door is closing fully.
3. Check door seals on all corners

TICK BOX

<input type="checkbox"/>
<input type="checkbox"/>
<input type="checkbox"/>
<input type="checkbox"/>
<input type="checkbox"/>
<input type="checkbox"/>

6 OPERATION (CREW USE)

1. TEMPERATURE

RECOMMENDED FRIDGE TEMP + 5

Follow instructions below to change the temperature on thermostat

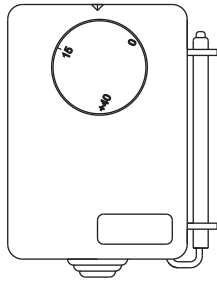

MECHANICAL THERMOSTAT

Mechanical Thermostat 0c to 40c

1. Temperature is shown on the dial in degrees centigrade.
2. Use the indicator mark at the top of the thermostat to align the dial.
3. Recommended setting +5 for a fridge.

2. DRAINS

Fridge drains are connected to grey water system and will not drain with grey water system turned off. A water trap (U-bend) is required in the drain pipe to stop air entering the fridge and causing ice build up on the wall evaporator this reducing performance.

3. DOOR SEALS

Door seals MUST be air tight and in good condition. A bad seal will allow air to enter cabinet causing ice build up on the wall evaporator thus reducing performance. Replacement seals are available from Penguin Refrigeration Ltd.

4. DOOR HEATERS

Each door has a heated seal which can be confirmed as working by touching the grey plastic door surround.

5. FANS & LIGHTS

Fans and lights turn ON/OFF with the door. The fan should stop when the door is opened and the light should come on.

4. STORAGE OF FOOD

Freezers are for storing frozen food. As with fridges DO NOT OVER PACK, leave free space in front of fan.

5. CLEAN & DEFROST

Freezers require defrosting only if ice build up is excessive.

6. SPARES & REPAIRS

All spare parts are available from Penguin Refrigeration. Please photograph the part and e-mail along with the boat name/ number to: sales@penguinfrigo.co.uk

7. SERVICE

Please call Penguin Refrigeration or Veco before appointing any engineers for general service or warranty work.

INSTALLATION NOTES - MS 115 IN (G51365)