

**INSTALLATION INSTRUCTIONS 1-6 MUST BE FOLLOWED TO VALIDATE THE WARRANTY**

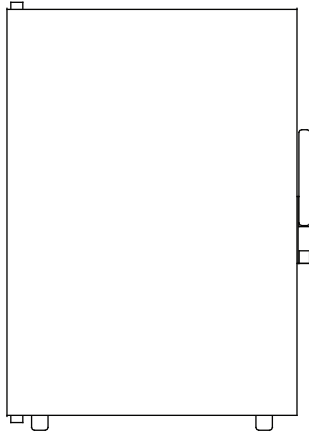

- |          |                           |                          |
|----------|---------------------------|--------------------------|
| <b>1</b> | Minimum Space Requirement | <input type="checkbox"/> |
| <b>2</b> | Drainage                  | <input type="checkbox"/> |
| <b>3</b> | Electrical                | <input type="checkbox"/> |
| <b>4</b> | Fitting                   | <input type="checkbox"/> |
| <b>5</b> | Compressor Installation   | <input type="checkbox"/> |
| <b>6</b> | Thermostat                | <input type="checkbox"/> |

INSTALLATION NOTES -MS 130 STD (G50841)

**1 RECOMMENDED SPACE REQUIREMENTS**

When installing the cabinet it is essential that + - 5mm is left to either side and top of the cabinet to allow for sufficient air circulation. 40mm must also be left at the back of the cabinet to allow for pipes.

**CABINET DIMENSIONS**

**Width:** 530mm  
**Height:** 745mm  
**Depth:** 480mm  
 (excluding door)  
**Door:** 50mm

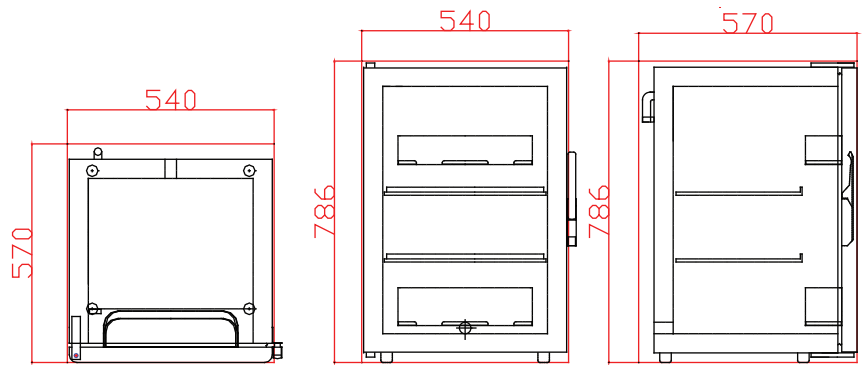

Recommended space required around cabinet (with remote mounted compressor) to allow for sufficient air circulation: 540(w) x 786(h) x 570(d)mm

**2 DRAINAGE**

All fridge drains **MUST** be fitted with U-bends and must be connected to the food hygiene grey water system.

All fridges will be supplied with a drain fixing kit which allows the drain to be installed correctly with a U-bend.

The drain fixing kit must be installed in a suitable position where the pigtail hangs vertically to allow a sufficiently sized water trap to be created (see drawing). It must be located below the drain exit (A).

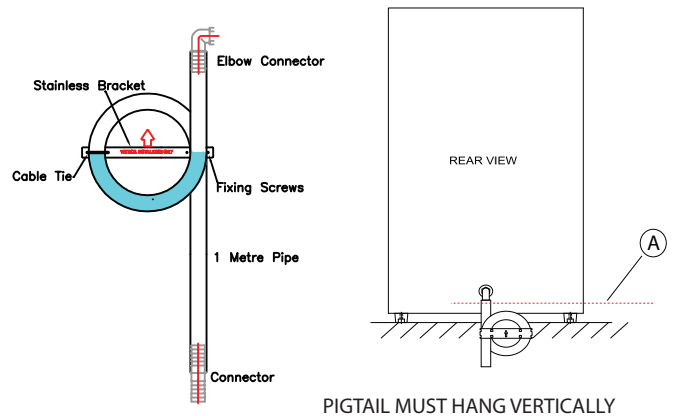

### 3 ELECTRICAL

#### MULTIVOLTAGE CONTROLLER

Supply Voltage 12/24v and or 110/220v 50~60hz

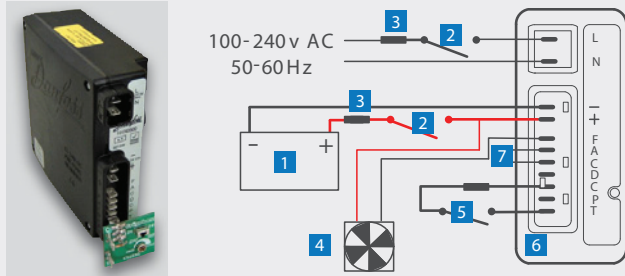

- 1 Battery
- 2 Isolation switch
- 3 Fuses correctly rated (DC 12v 15 amp - 24v 8 amp) (AC 220v 4 amp)
- 4 Fan DC
- 5 Thermostat
- 6 Optional speed board
- 7 DC light

#### BASIC CONTROLLER

Supply Voltage 12/24v

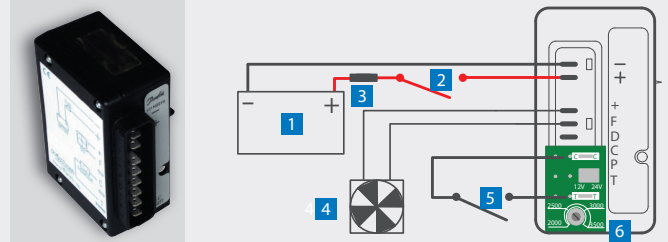

- 1 Battery
- 2 Isolation switch
- 3 Fuse (12v 15amp- 24v 8amp)
- 4 Fan
- 5 Thermostat
- 6 Optional speed board

### 4 FITTING

#### FRONT FIXING

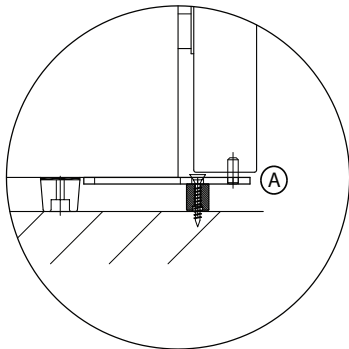

#### FIXING BRACKETS

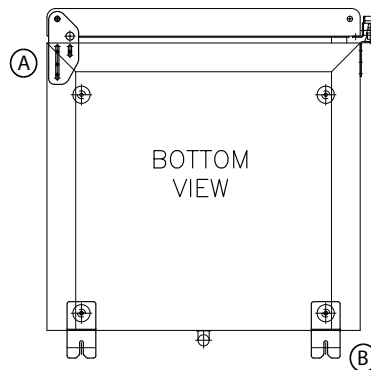

#### BACK FIXING

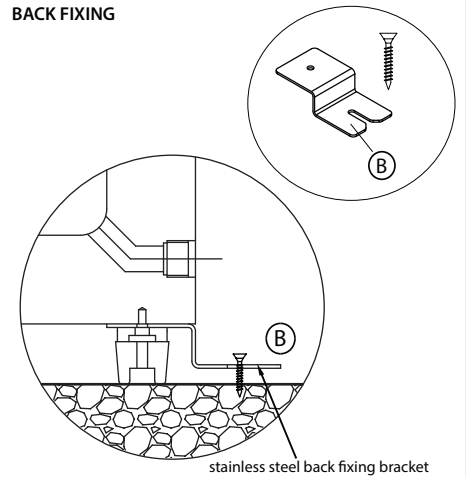

### 5 COMPRESSOR INSTALLATION

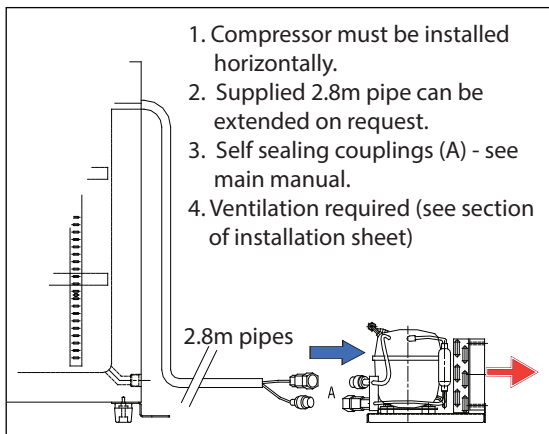

### 6 THERMOSTAT

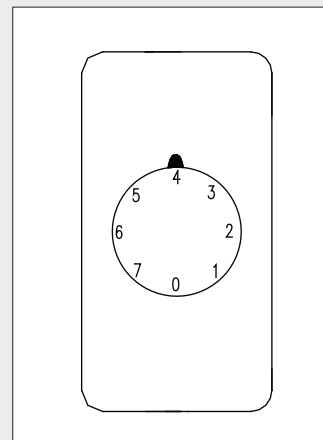

#### Mechanical Thermostat 0 - 7

1. Dial settings 0-7 (0 = OFF, 1-7 increasing degrees of coolness with 7= coldest)
2. Set the dial to position 5 at first and check if cold enough. To make colder increase to setting 6 or 7. To make less cold decrease as required.

## 4 PRE-COMMISSIONING CHECKS

### PRE-CHECKS TO BE CARRIED OUT BEFORE COMMISSIONING

#### PRE-CHECKS 1st RUN

1. Check all refrigerant pipes have been connected by plumbers (ensure coupling connections are fully made).
3. Check all electrical connections are made by electricians.
4. Install shelves and check door is fitted.

#### PRE-COMMISSIONING 1st RUN

1. Turn on power at breakers and set thermostat dial to position 7.
2. Check compressor is running.
3. **Cabinet should then be left to cool before carrying out commissioning.**

## 5 COMMISSIONING

### PLEASE ENSURE PRE-COMMISSIONING CHECKS ARE CARRIED OUT BEFORE COMMISSIONING CABINET

#### TO TEST FRIDGE CABINET

TICK BOX

- |  |  |
|--|--|
| <ol style="list-style-type: none"> <li>1. Turn on power at breaker</li> <li>2. Set temperature on thermostat dial to position 7</li> <li>3. Check compressor is running</li> <li>4. Check white evaporator inside cabinet is frozen all over.</li> <li>5. When ice box is frozen, turn thermostat dial to 3 and check compressor turns off.</li> </ol> | <input type="checkbox"/><br><input type="checkbox"/><br><input type="checkbox"/><br><input type="checkbox"/><br><input type="checkbox"/> |
|--|--|

#### ADDITIONAL CHECKS

Once cabinet has been confirm as working, turn on fridge and carry out the following additional checks:

TICK BOX

- |  |  |
|--|--|
| <ol style="list-style-type: none"> <li>1. Check drain is connected and U-bend fitted</li> <li>2. Check drain is draining properly by pouring 1/2 bucket of water down it</li> <li>3. Check interior light is switching ON/OFF when door is opened and closed</li> <li>4. Check door heater seal is working (use infared thermometer over grey plastic)</li> <li>2. Check shelves are installed correctly and door is closing fully.</li> <li>3. Check door seals on all corners</li> </ol> | <input type="checkbox"/><br><input type="checkbox"/><br><input type="checkbox"/><br><input type="checkbox"/><br><input type="checkbox"/><br><input type="checkbox"/> |
|--|--|

## 6 OPERATION (CREW USE)

### 1. TEMPERATURE

RECOMMENDED FRIDGE TEMP + 5

Follow instructions below to change the temperature on thermostat

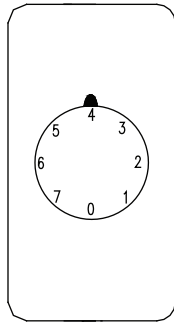

#### MECHANICAL THERMOSTAT 0 - 7

1. Dial settings 0 - 7 (0 = OFF, 1 - 7 increasing degrees of coolness with 7 = coldest)
2. Set the dial to position 5 at first and check if required temperature. To make colder increase to dial setting 6 or 7. To make less cold decrease as required.

### 2. DRAINS

Fridge drains are connected to grey water system and will not drain with grey water system turned off. A water trap (U-bend) is required in the drain pipe to stop air entering the fridge and causing ice build up on the wall evaporator this reducing performance.

### 3. DOOR SEALS

Door seals MUST be air tight and in good condition. A bad seal will allow air to enter cabinet causing ice build up on the wall evaporator thus reducing performance. Replacement seals are available from Penguin Refrigeration Ltd.

### 4. DOOR HEATERS

Each door has a heated seal which can be confirmed as working by touching the grey plastic door surround.

### 5. FANS & LIGHTS

Fans and lights turn ON/OFF with the door. The fan should stop when the door is opened and the light should come on.

### 4. STORAGE OF FOOD

Freezers are for storing frozen food. As with fridges DO NOT OVER PACK, leave free space in front of fan.

### 5. CLEAN & DEFROST

Freezers require defrosting only if ice build up is excessive.

### 6. SPARES & REPAIRS

All spare parts are available from Penguin Refrigeration. Please photograph the part and e-mail along with the boat name/ number to: sales@penguinfrigo.co.uk

### 7. SERVICE

Please call Penguin Refrigeration or Veco before appointing any engineers for general service or warranty work.