

Climma Variable Power Chilled Water Systems

- Zero additional start load
- Unique water cooled inverter delivers modulated power
- Up to 50% energy saving in Eco mode
- Eco friendly R410A refrigerant

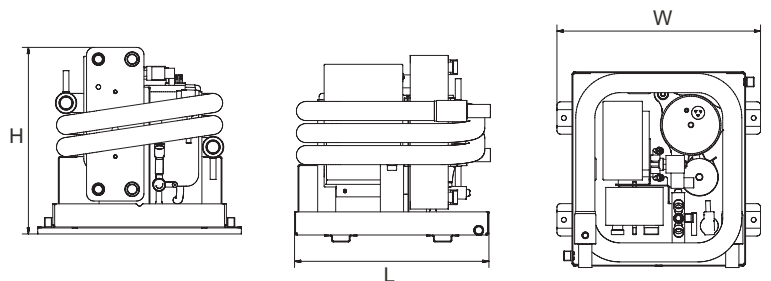
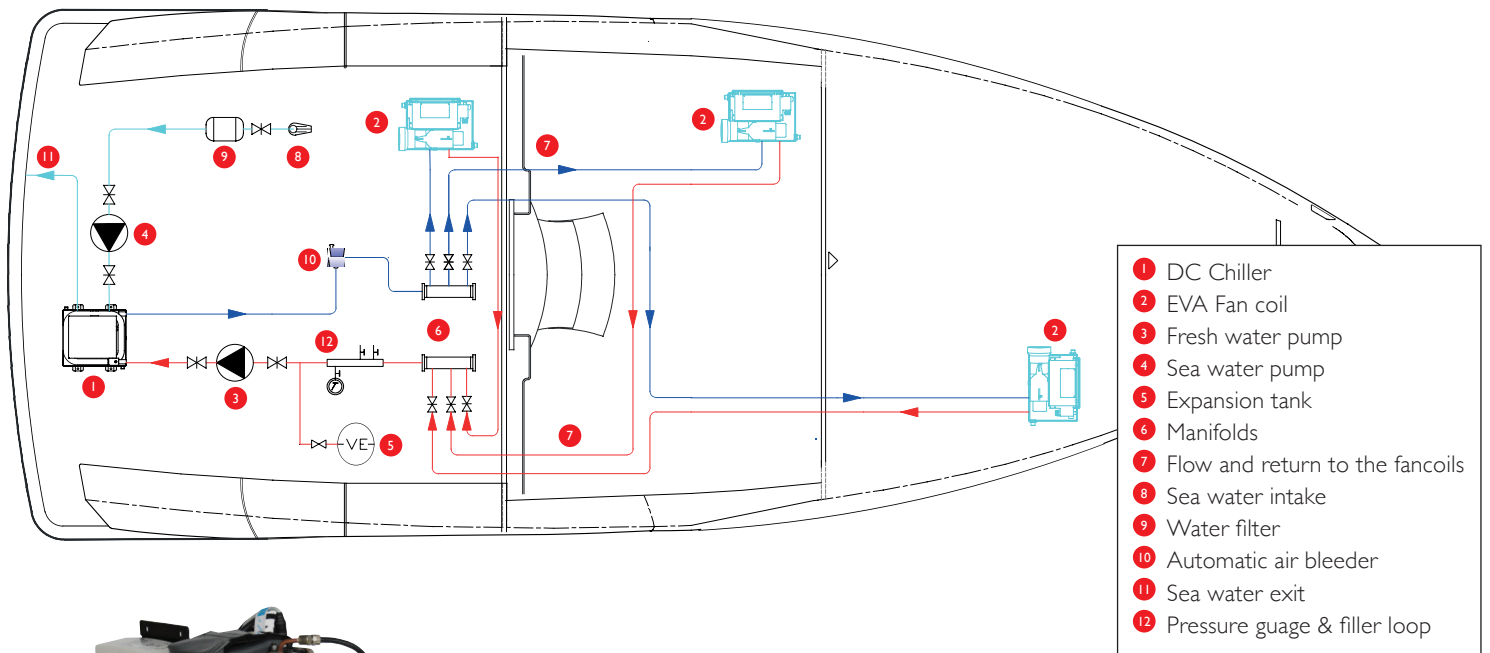

	DC40	DC50	DC65
POWER SUPPLY	230V/1/50-60Hz	230V/1/50-60Hz (or 400V/3/50-60Hz)	230V/1/50-60Hz (or 400V/3/50-60Hz)
Capacity (cool mode)	2,5 - 12 kW (8k - 40k Btu)	3 - 14 kW (10k - 50k Btu)	3,5kW - 19kW (12k - 65k Btu)
Capacity (heat mode)	3 kW - 13 kW (10k - 45k Btu)	4 kW - 16 kW (13k - 55k Btu)	5kW - 20,5kW (17k - 70k Btu)
Power consumption (a) - cool mode	2,5 A - 16 A	3 A - 18 A	3A - 23A
Power consumption (kW) - cool mode	0,3 kW - 3,2 kW	0,5 kW - 4 kW	0,5kW - 5,2kW
Start current (a)	0 A	0 A	0 A
FRESH WATER FLOW (m3/h)	2 m3/h	2 m3/h	3 m3/h
SEA WATER FLOW (m3/h)	2 m3/h	2 m3/h	3 m3/h
Sea water temp. (heat mode)	> 5 °C	> 5 °C	> 5 °C
Sea water temp. (cool mode)	< 40 °C	< 40 °C	< 40 °C
Refrigerant	R410a	R410a	R410a
SIZE (WxLxH in mm)	420x375x453	420x375x453	498,2x422,4x454
ELECTRICAL BOX (LxDxH in mm)	240x190x90	240x190x90	240x190x90
Weight (kg)	46	48	50
	£7,283.24	£8,363.60	£ 13,537.03

All prices are retail ex VAT

Climma Fan Coils - EVA Dry Pan

- Unique 'Dry Pan' system ensures condensate water will always drain (even when heeling)
- Highly efficient blowers are super quiet in operation with easy alignment to improve air flow
- Anti-vibration mounting system as standard
- Sizes from 4,500 to 24,000 BTU

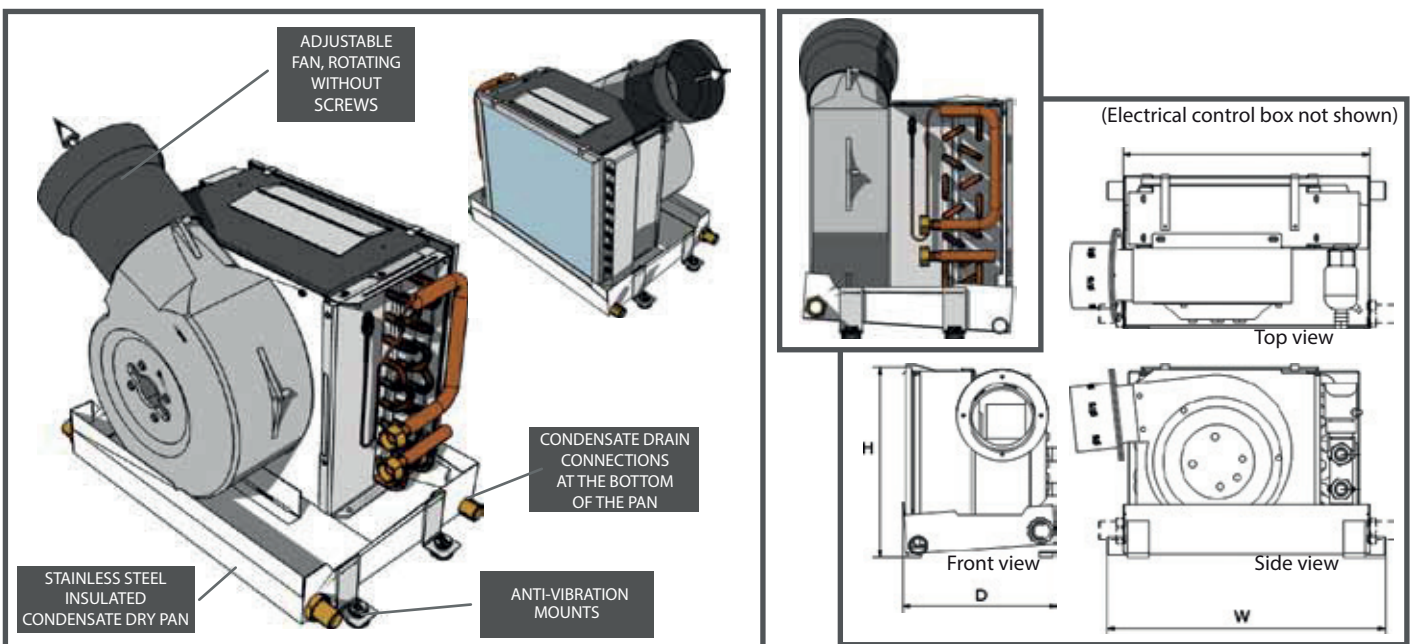

Fancoil	TECHNICAL									PRICES	
	Nominal Btu/h	Air Flow (mq3/h)	Duct Size (mm)	Fan (W)	Optional Heater (W)	Weight (kg)	Width (mm)	Depth (mm)	Height (mm)	Fan Coil & Control Box	Fan Coil Kit
MEVA4.5J	4,500	291	100	1x 125	1,300	6.4	377	288	304	£1,117.90	£1,435.84
MEVA7J	7,000	311	100	1x 125	1,300	7.6	377	288	304	£1,158.18	£1,476.12
MEVA9J	9,000	527	125	1x 235	1,300	8.0	377	288	304	£1,257.06	£1,637.93
MEVA13J	13,000	537	125	1x 235	1,300	8.7	377	308	304	£1,279.29	£1,657.16
MEVA15SJ SLIM	15,000	615	2x 100	2x 125	2,600	15.3	651	308	408	£1,767.14	£2,272.53
MEVA17J	17,000	915	150	1x 355	2,600	15.0	465	387	371	£1,499.68	£1,912.13
MEVA17SJ SLIM	17,000	1,080	2x 125	2x 235	2,600	18.5	651	408	308	£1,830.20	£2,335.59
MEVA17SJ EXTRA SLIM	17,000	1,080	2x 125	2x 235	2,600	15.5	651	300	308	£1,830.20	£2,335.59
MEVA24SJ SLIM	24,000	1,080	2x 125	2x 235	2,600	18.0	651	408	308	£1,936.40	£2,482.07
MEVA24SJ EXTRA SLIM	24,000	1,080	2x 125	2x 235	2,600	16.0	651	300	308	£1,936.40	£2,482.07
Digital display (Vega MkII)											£195.62
Optional water valve											£145.83
Optional strip heater											£192.78

Kits include:

Fancoil, Electrical control box, Vega MK2 Display, MCAV6 cable, 3m Duct, Back box and delivery grill.

* Does not include return air grill

All prices are retail ex VAT